

## Pneumatic rotary drive



Type 2051 can be combined with...



**Type 6518/6519**  
Solenoid valve



**Type 8792/93**  
Positioner SideControl



**Type 2654**  
Stainless steel ball valve

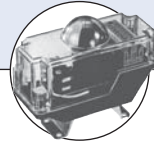

**Type TEUXXX**  
Position feedback



**Type 2671**  
Metal butterfly valve

- Modular program for mounting of quarter turn valves such as ball valves and butterfly valves
- NAMUR and ISO 5211 interfaces
- Position feedback (including Ex-Versions )
- SideControl Positioner ready

The 2051 pneumatic rotary drives are low maintenance single or double-acting pneumatic linear piston actuators where linear movement of the piston due to the pilot air causes a 90° rotation of the connected valve. Actuator-valve coupling is made via a universal ISO 5211 mechanical interface and the status of ball or butterfly valve can be monitored at a control system through a range of rugged feedback switches. The drives can also be used as modulating control actuators by the addition of Bürkert's range of SideControl positioners.

### Control function A

Single-acting actuator return by spring, operating e.g. with pilot valve

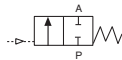

### Control function I

Double-acting actuator, operating e.g. with pilot valve

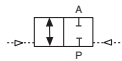

### Control function B

Single-acting actuator return by spring

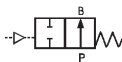

Function principles see p. 3

Technical data	
<b>Materials</b>	
Actuator	aluminium alloy
Piston	aluminium
Seal	special NBR
<b>Control medium</b>	filtered compressed air with or without oil
<b>Control pressure</b>	3-8 bar single-acting 2.5-8 bar double-acting max. 8 bar
<b>T<sub>umg</sub></b>	-40 up to + 80 °C (FKM: -15 up to +150 °C)
<b>Rotation</b>	90°, adjustable before -5 up to 95°
<b>Adjustable angle</b>	every 20°
<b>Interface</b>	
Pilot air ports	NAMUR Flange interface VDE/VDI 3845 Size 10-100: G 1/8, Size 150-450: G 1/4
Feedback signal	NAMUR VDE/VDI 3845
Fittings	ISO 5211

## Ordering chart (other versions on request)

## Double-acting actuator (Control function I)

Actuator-size	Torque (Nm) dependent on control pressure							Air volume(l)		Weight [kg]	Item no.
	Control pressure (bar)							opening	closing		
	3	4	5	5,5	6	7	8				
15	10	13.3	16.6	18.3	19.9	23.3	26.6	0.09	0.15	1	214 520
30	17.6	23.5	29.3	32	35.2	41	46.9	0.16	0.26	1.6	214 522
60	34.9	46.5	58.2	64	69.8	81.4	93.1	0.31	0.49	2.7	214 524
100	54.9	73.2	91.5	101	110	128	146	0.51	0.78	3.7	214 525
150	79.8	106	133	146	160	186	213	0.71	1.11	5.2	214 526
220	129	172	215	236	258	301	344	1.19	1.8	8	214 527
300	166	222	277	305	332	388	433	1.54	2.34	9.8	214 528

## Single-acting actuator (Control function A, 6 spring packages per side)

Actuator size	Torque (Nm) dependent on control pressure								Air volume(l)			Item no. (Control function A)	Item no. (Control function B)
	Control pressure (bar)								opening	closing	Weight [kg]		
	5,5		6		8		spring force						
0°	90°	0°	90°	0°	90°	90°	0°	opening	closing	Weight [kg]	Item no. (Control function A)	Item no. (Control function B)	
15	10.2	6.6	11.9	8.2	18.5	14.9	11.7	8.1	0.09	0.15	1.1	214 529	214 537
30	18.9	12	21.9	14.9	33.6	26.7	20.2	13.3	0.16	0.26	1.7	214 530	214 538
60	37.5	22.4	43.3	28.3	66.5	51.5	41.5	26.5	0.31	0.49	3.1	214 531	214 539
100	56.7	31.4	65.8	40.5	102	77.1	69.3	44	0.51	0.78	4.3	214 532	214 540
150	85.4	51.7	99	65	152	118	94.5	60.8	0.71	1.11	6.1	214 533	214 541
220	138	79	159	101	245	187	157	98.4	1.19	1.8	9.3	214 534	214 542
300	179	107	206	135	317	245	198	126	1.54	2.34	12	214 535	214 543
450	281	169	324	213	498	386	309	198	2.41	3.78	17	214 536	214 545

## Ordering chart – Accessories

Specifications	Item no.
universal adapter for shaft	787 338
universal assembly bridge	770 294

## Functional principle

### Control function A

Air supplied to Port "2" forces the pistons toward the actuator end caps, compressing the springs. A counter-clockwise rotation is achieved. Exhaust air exits from Port 4.

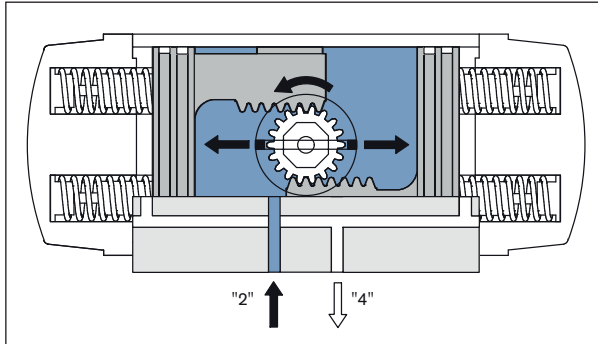

The loss of air pressure (air or electric failure) at Port "2" allows the springs to force the pistons inward. A clockwise rotation is achieved. Exhaust air exits from Port 2.

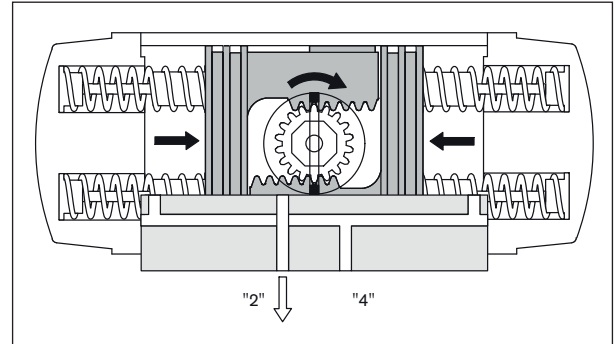

### Control function B

Is the opposite rotating direction of control function A.

### Control function I

Air supplied to port 2 forces the pistons towards the actuator end caps. A counter-clockwise rotation is achieved. Exhaust air exits from Port 4.

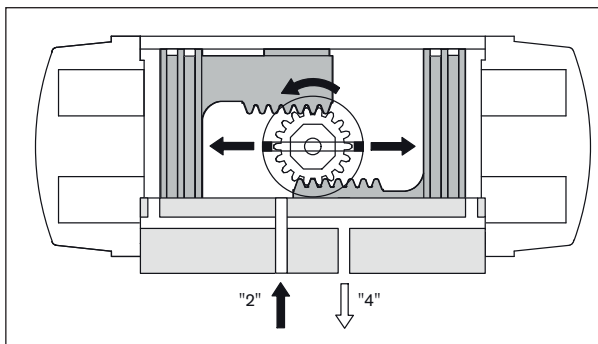

Air supplied to Port 4 forces the pistons inward. A clockwise rotation is achieved. Exhaust air exits from Port 2.

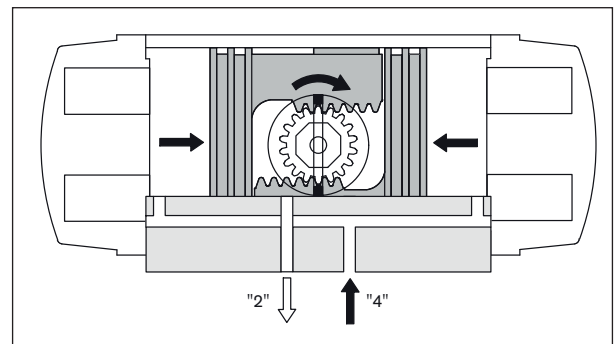

Note: Top view

Dimensions [mm]

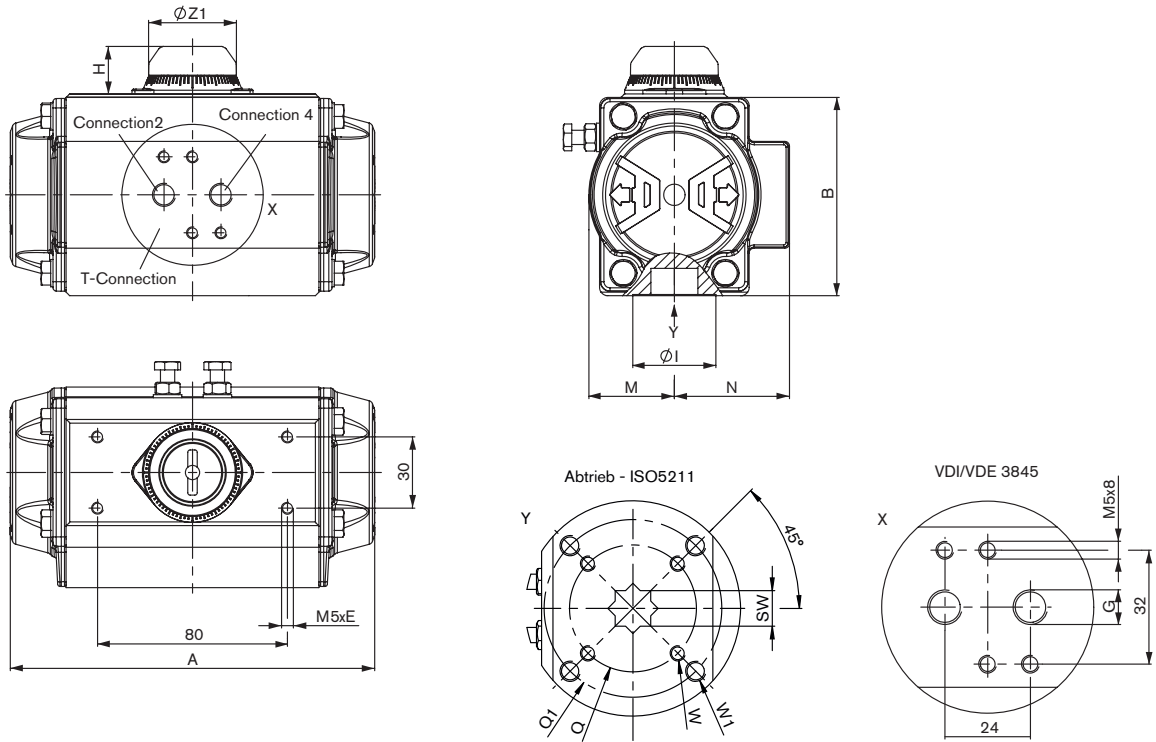

Size	A	B	E	H	ØI	M	N	Q	Q1	W	W1	ØZ1	G	SW	ISO 5211
15	136	69	4	20	30	29	43	36	50	M5	M6	37	1/8"	11	F03-05
30	153.5	85	8	20	35	36	48.5	50	70	M6	M8	37	1/8"	14	F05-07
60	203.5	102	8	20	35	42.5	50.5	50	70	M6	M8	37	1/8"	14	F05-07
100	241	115	8	20	55	49.5	56.5	50	70	M6	M8	37	1/8"	17	F05-07
150	259	127	8	20	55	55.5	63	70	102	M8	M10	37	1/4"	17	F07-10
220	304	145	8	30	70	64	72	70	102	M8	M10	51	1/4"	22	F07-10
300	333	157	8	30	70	69.5	77	70	102	M8	M10	51	1/4"	22	F07-10
450	394.5	177	8	30	85	80	86	102	125	M10	M12	60	1/4"	27	F10-12

DTS 1000104926 EN Version: J Status: RL (released | freigegeben | valide) printed: 19.01.2015

To find your nearest Bürkert facility, click on the orange box → [www.burkert.com](http://www.burkert.com)

In case of special application conditions, please consult for advice.

Subject to alteration.  
© Christian Bürkert GmbH & Co. KG

1407/9\_EU-en\_00895035